

SSM-FDH HIGH TEMPERATURE S-TYPE LOAD CELL (U.S. & METRIC)

FEATURES & BENEFITS

- Proprietary Interface temperature compensated strain gages
- Environmentally sealed
- Tension and compression

SPECIFICATIONS

ACCURACY – (MAX ERROR)				
Nonlinearity – %FS		±0.05		
Hysteresis – %FS		±0.03		
Non-repeatability – %RO		± 0.02		
Creep, in 20 min – %		± 0.03		
TEMPERATURE				
Compensated Range	°F	0 to +300		
	°C	-20 to +150		
Operating Range	°F	-65 to +320		
	°C	-50 to +160		
Effect on Output – % MAX	°F	±0.0008		
	°C	±0.0015		
Effect on Zero – %RO MAX	°F	±0.0008		
	°C	±0.0015		
ELECTRICAL				
Rated Output – mV/V (Nominal)		3		
Zero Balance – %RO		±1		
Bridge Resistance – Ohm (Nominal)		350		
Excitation Voltage – VDC MAX		15		
Insulation Resistance – Megohm		> 5000		
MECHANICAL				
Calibration		Tension		
Safe Overload – %CAP		150		
NATURAL FREQUENCY/DEFLECTION				
lbf	N	Deflection		Nat. Freq. (Hz)
		in	mm	
50	200	0.08	0.003	1500
100	500	0.004	0.10	1850
150	700	0.004	0.10	1850
250	1K	0.006	0.15	2350
Material		Aluminum		

STANDARD CONFIGURATION



MODEL SSM-FDH (Shown)

OPTIONS

- Add connector to cable
- Standardized output
- Cable length
- Transducer electronic Data Sheet (TEDS)

ACCESSORIES

- Instrumentation
- Mounting hardware
- Load button

CONNECTOR OPTIONS

- 15 ft (4.5 m) integral cable

SSM-FDH HIGH TEMPERATURE S-TYPE LOAD CELL (U.S. & METRIC)

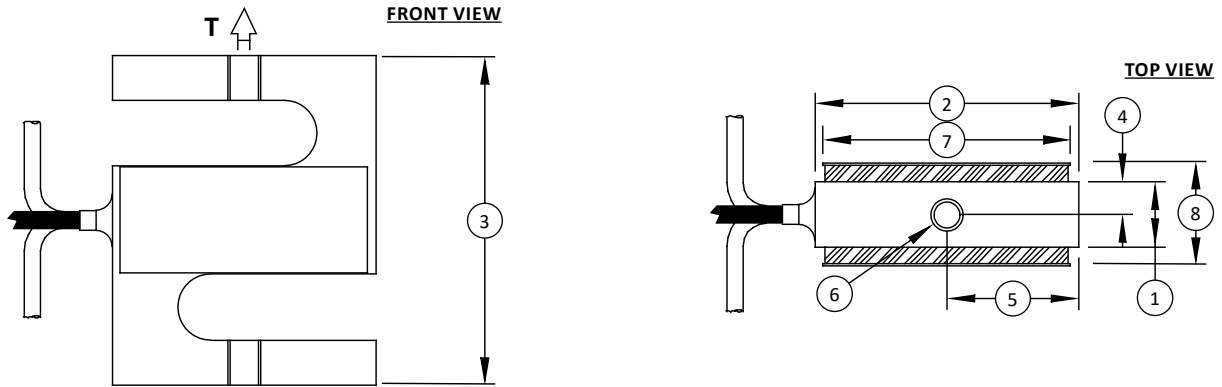

Notes:
 * T indicates tension load direction / primary axis

See Drawing	CAPACITY			
	U.S. (lbf)	Metric (N)	U.S. (lbf)	Metric (N)
	50, 100, 150, 250	200, 500, 700, 1K	500, 1K	2K, 5K
	in	mm	in	mm
(1)	0.50	12.7	1.00	25.4
(2)	2.00	50.8	2.00	50.8
(3)	2.50	63.5	3.00	76.2
(4)	0.25	6.40	0.50	12.7
(5)	1.00	25.4	1.00	25.4
(6)	¼-28 UNF-2B	M6 x 1-6H	½-20 UNF-2B	M12 x 1.75-6H
(7)	1.88	47.8	1.88	47.8
(8)	0.72	18.3	1.22	31.0