

## 3A SERIES 3-AXIS LOAD CELLS (U.S. & METRIC)

### FEATURES & BENEFITS

- 3-Axis – Fx Fy Fz; independent bridges
- 20N to 500kN (4.5 to 112K lbf) force range
- Compact size
- Low crosstalk
- Temperature compensated

Interface's 3-axis load cell measures forces simultaneously in 3 mutually perpendicular axes: X, Y, and Z - tension and compression. Each axis provides a unique mV/V output and requires no mathematical manipulation. The 3-axis load cell is built to minimize eccentric loading effects and crosstalk between axes.

The 3A Series 3-axis load cell is ideally suited to many industrial and scientific applications, such as aerospace, robotics, automotive and medical research (orthopedics and biomechanical).

The load cell is provided in various capacity ranges and sizes with each of the three axes providing the same capacity.

We are happy to work with your design needs – providing a custom design if warranted for varying capacities (between X, Y, and Z), higher temperature capability, or OEM/private labeling if needed.

### WIRING DIAGRAM

	Description	Wire Color	37-pin D-SUB	16-pin M23
Shield	Shield	Shield	1	N/C
X-Axis	+ Excitation	Brown	20	2
	- Excitation	White	27	1
	+ Output	Green	22	3
	- Output	Yellow	25	4
Y-Axis	+ Excitation	Pink	2	6
	- Excitation	Gray	9	5
	+ Output	Blue	4	7
	- Output	Red	7	8
Z-Axis	+ Excitation	Purple	11	10
	- Excitation	Black	18	9
3A60A	+ Output	Orange	13	11
	- Output	Transparent	16	12
3A120, 3A160, 3A300, & 3A400	+ Output	Gray/Pink	13	11
	- Output	Red/Blue	16	12

### STANDARD CONFIGURATION



Model 3A60A (Shown)

### ACCESSORIES



Model BSC4D (Shown)  
4-Channel Analog Amplifier



Model BSC4A (Shown)  
4-Channel USB Digital Amplifier

\* U.S. dimensions and capacities are provided for conversion only. Standard product will be sold in kN and Metric dimensions. U.S. capacities available upon special request and at an additional cost.

## 3A60A SERIES 3-AXIS LOAD CELL (U.S. & METRIC)

### SPECIFICATIONS

ACCURACY – (MAX ERROR*)							
Nonlinearity – %FS		±0.2					
Hysteresis – %FS		±0.02					
Creep, in 30 min – %		±0.1					
TEMPERATURE							
Effect on Zero – %RO / °C		±0.02					
Effect on Output – % / °C		±0.02					
Compensated Range	°C	-10 to +70					
	°F	+14 to +158					
Operating Range	°C	-10 to +85					
	°F	+14 to +185					
ELECTRICAL							
Rated Output (Nominal) – mV/V		±0.5					
Max. Excitation Voltage – V		10					
Zero balance – mV/V		0.1					
Input resistance, x/y axis – Ω		395 ±5			375 ±5		
Output resistance, z axis – Ω		355 ±5					
Insulation Resistance – Ω		> 5 × 10 <sup>9</sup>					
Electrical Connection – m		5 Cable with 37-PIN Connector. Includes Mate					
MECHANICAL							
Rated Capacity (FS)	N	10	20	50	100	200	500
	lbf	2.25	4.5	11.2	22.5	45	112
Material		Aluminum				Stainless steel	
Deflection – Fx, Fy	mm	0.10				0.20	
	in	0.004				0.008	
Deflection – Fz	mm	0.15					
	in	0.006					
Total Weight	kg	0.110				0.2	
	lbs	0.2425				0.44	
Safe Overload – %RO		150					
Ultimate Overload – %RO		300					
Protection Level		IP54					
ECCENTRICITY AND MOMENT*							
Allowable moment – Nm	Nm	20				50	
	lbf-in	177				443	
Crosstalk: x:y / y:x – %		±2					
Crosstalk: z:x/y – %		±2					
Crosstalk: x/y:z – %		±2					
Eccentric Load Sensitivity – %FS @ 20mm (0.8 in)		±1					

### STANDARD CONFIGURATION



**Model 3A60A (Shown)**

### FEATURES & BENEFITS

The 3A60A is a new and improved version of the original 3A60 with revised mounting holes and extended capacity ranges. The 3A60A is NOT backward compatible with the old 3A60.

\* Nominal

U.S. dimensions and capacities are provided for conversion only. Standard product will be sold in kN and Metric dimensions. U.S. capacities available upon special request and at an additional cost.

## 3A60A SERIES 3-AXIS LOAD CELL (U.S. & METRIC)

### DIMENSIONS

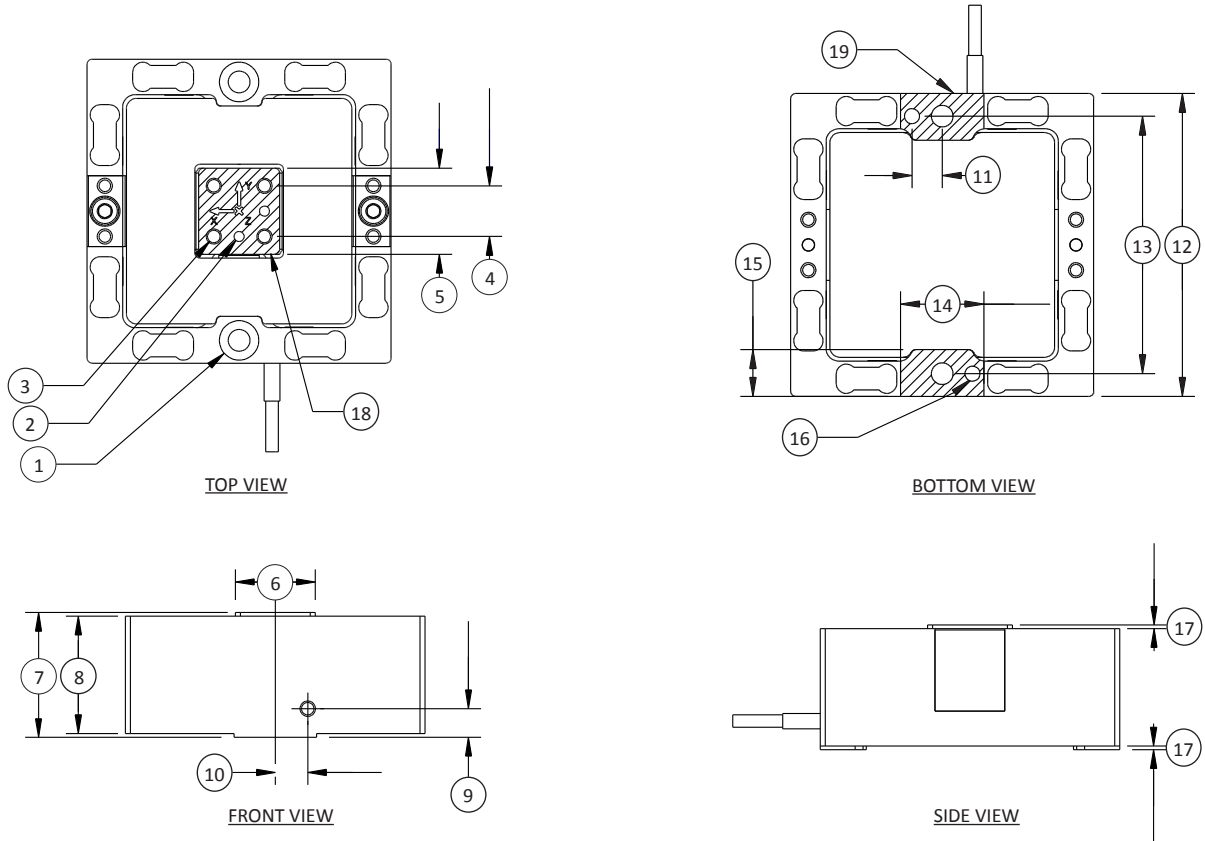

See Drawing	Metric	U.S.
	mm	in
(1)	2 x $\varnothing 4.3 \downarrow 24.25$ , $\square 7.8 \downarrow 17.25$	2 x $\varnothing 0.17 \downarrow 0.955$ , $\square 0.31 \downarrow 0.679$
(2)	2 x $\varnothing 2 E7 \downarrow 5$ , $\sphericalangle 118^\circ$	2x $\varnothing(0.0797/0.0793) \downarrow 0.2$ , $\sphericalangle 118^\circ$
(3)	4 x (M3X0.5) $\downarrow 10$ , $\sphericalangle 118^\circ$	4 x (M3X0.5) $\downarrow 0.4$ , $\sphericalangle 118^\circ$
(4)	10	0.4
(5)	17	0.7
(6)	16	0.6
(7)	25	1.0
(8)	23.5	0.9
(9)	5.75	0.226
(10)	6.5	0.3
(11)	6	0.2
(12)	60	2.4
(13)	51	2.0
(14)	16.5	0.6
(15)	9.25	0.4
(16)	2 x $\varnothing 3 E7 \downarrow 5$ , $\sphericalangle 118^\circ$	2x $\varnothing(0.1191/0.1187) \downarrow 0.2$ , $\sphericalangle 118^\circ$
(17)	0.75	0.030
(18)	Bolting Surface / Measuring Platform	
(19)	Bolting Surface	

U.S. dimensions and capacities are provided for conversion only. Standard product will be sold in kN and Metric dimensions. U.S. capacities available upon special request and at an additional cost.

## 3A120 SERIES 3-AXIS LOAD CELL (U.S. & METRIC)

### SPECIFICATIONS

### STANDARD CONFIGURATION



Model 3A120 (Shown)

ACCURACY – (MAX ERROR*)									
Nonlinearity – %FS		±0.2							
Hysteresis – %FS		±0.02							
Creep, in 30 min – %		±0.1							
TEMPERATURE									
Effect on Zero – %RO / °C		±0.02							
Effect on Output – % / °C		±0.02							
Compensated Range	°C	-10 to +70							
	°F	+14 to +158							
Operating Range	°C	-10 to +85							
	°F	+14 to +185							
ELECTRICAL									
Rated Output (Nominal) – mV/V		±0.5	±1						
Max. Excitation – V		10							
Zero balance – mV/V		0.1							
Input resistance, x/y axis – Ω		780 ±5				740 ±5			
Output resistance, z axis – Ω		700 ±5							
Insulation Resistance – Ω		> 5 × 10 <sup>9</sup>							
Electrical Connection – m		5 Cable with 37-PIN Connector. Includes Mate							
MECHANICAL									
Rated Capacity (FS)	N	50	100	200	500	1K	1K**	2K	5K
	lbf	11.2	22.5	45	112	225	225	450	
Material		Aluminum				Stainless steel			
Deflection – Fx, Fy	mm	0.06				0.08			
	in	0.002				0.003			
Deflection – Fz	mm	0.12				0.16			
	in	0.005				0.006			
Total Weight	kg	1.1				2.0			
	lbs	2.43				4.41			
Safe Overload – %RO		150							
Ultimate Overload – %RO		300							
Protection Level		IP54 (option IP68)							
ECCENTRICITY AND MOMENT*									
Allowable moment	Nm	100				200	250	300	
	lbf-in	885				1.77K	2.21K	2.66K	
Crosstalk: x:y / y:x – %		±1							
Crosstalk: z:x/y – %		±2							
Crosstalk: x/y:z – %		±1							
Eccentric Load Sensitivity – %FS @ 100mm (3.9 in)		±1							

\* Nominal

\*\* Stainless Version denoted by 3A120S-1KN

U.S. dimensions and capacities are provided for conversion only. Standard product will be sold in kN and Metric dimensions. U.S. capacities available upon special request and at an additional cost.

## 3A120 SERIES 3-AXIS LOAD CELL (U.S. & METRIC)

### DIMENSIONS

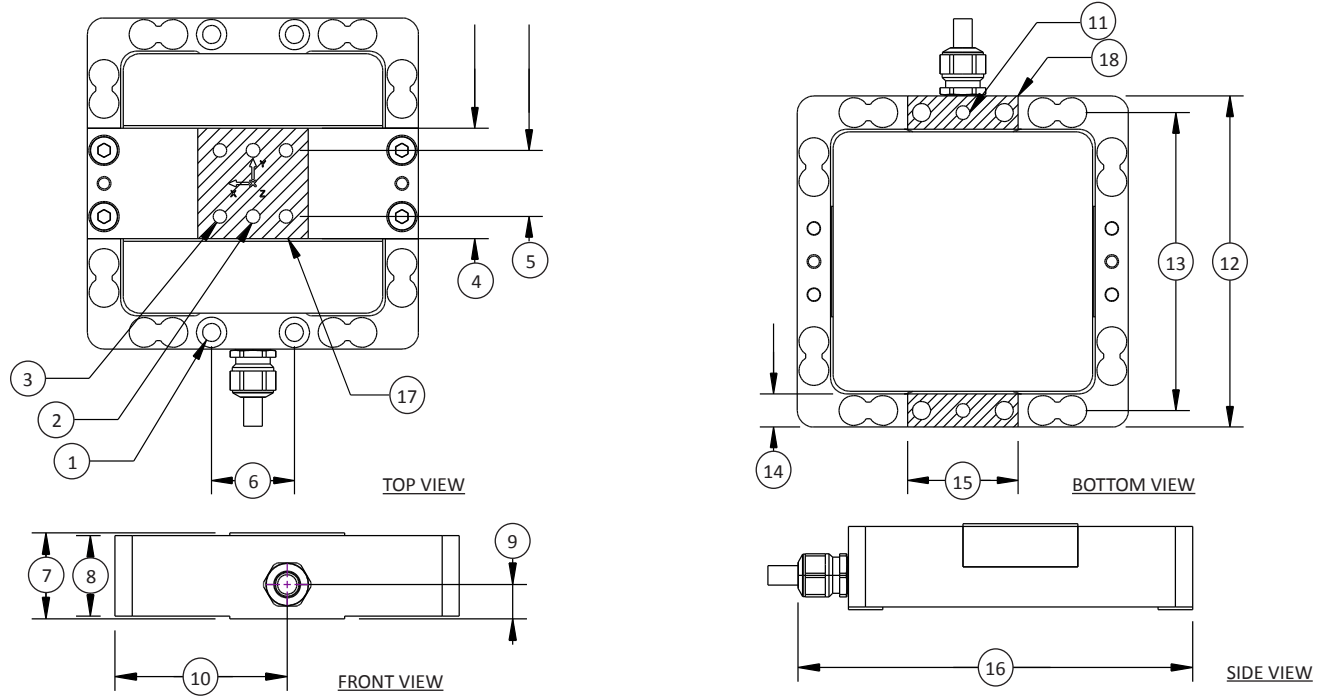

See Drawing	Metric	U.S.
	mm	in
(1)	4 x $\varnothing 6.6 \downarrow 29 \sphericalangle 118^\circ$ , $\square \varnothing 11.0 \downarrow 22.5$	4 x $\varnothing 0.26 \downarrow 1.1 \sphericalangle 118^\circ$ , $\square \varnothing 0.43 \downarrow 0.89$
(2)	2 x $\varnothing 5 E7 \downarrow 12, \sphericalangle 118^\circ$	2 x $\varnothing (0.1981/0.1976) \downarrow 0.5, \sphericalangle 118^\circ$
(3)	4 x (M6x1) $\downarrow 12$	4 x (M6x1) $\downarrow 0.5$
(4)	40	1.6
(5)	24	0.9
(6)	30	1.2
(7)	30	1.2
(8)	28	1.1
(9)	12	0.5
(10)	60	2.4
(11)	2 x $\varnothing 5 E7 \downarrow 3$	2 x $\varnothing (0.1981/0.1976) \downarrow 0.1$
(12)	120	4.7
(13)	108	4.3
(14)	12	0.5
(15)	40	1.6
(16)	137.5	5.4
(17)	Bolting Surface / Measuring Platform	
(18)	Bolting Surface	

## 3A160 SERIES 3-AXIS LOAD CELL (U.S. & METRIC)

### SPECIFICATIONS

### STANDARD CONFIGURATION

ACCURACY – (MAX ERROR*)			
Nonlinearity – %FS		±0.2	
Hysteresis – %FS		±0.1	
Creep, in 30 min – %		±0.05	
TEMPERATURE			
Effect on Zero – %RO / °C		±0.02	
Effect on Output – % / °C		±0.02	
Compensated Range	°C	-10 to +70	
	°F	+14 to +158	
Operating Range	°C	-10 to +85	
	°F	+14 to +158	
ELECTRICAL			
Rated Output (Nominal) – mV/V		±1	
Max. Excitation Voltage – V		10	
Zero balance – mV/V		0.1	
Input resistance, x/y axis – Ω		740 ±5	
Output resistance, z axis – Ω		700 ±5	
Insulation Resistance – Ω		> 5 × 10 <sup>9</sup>	
Electrical Connection – m		5 Cable with 37-PIN Connector. Includes Mate	
MECHANICAL			
Rated Capacity (FS)	N	2K - 10K	20K    50K
	lbf	450 - 2.25K	4.5K    11.2K
Material		Nickel plated steel	
Deflection – Fx, Fy – mm	mm	0.08	
	in	0.003	
Deflection – Fz – mm	mm	0.16	
	in	0.006	
Total Weight – kg	kg	8.2	
	lbs	18.08	
Safe Overload – %RO		150	
Ultimate Overload – %RO		300	
Protection Level		IP54	
ECCENTRICITY AND MOMENT*			
Allowable moment	Nm	1K	2K
	lbf-in	8.85K	17.7K
Crosstalk: x:y / y:x – %		±1	
Crosstalk: z:x/y – %		±2	
Crosstalk: x/y:z – %		±2	
Eccentric Load Sensitivity – %FS @ 20mm (2.0 in)		±1	



**Model 3A160 (Shown)**

\* Nominal

U.S. dimensions and capacities are provided for conversion only. Standard product will be sold in kN and Metric dimensions. U.S. capacities available upon special request and at an additional cost.

## 3A160 SERIES 3-AXIS LOAD CELL (U.S. & METRIC)

### DIMENSIONS

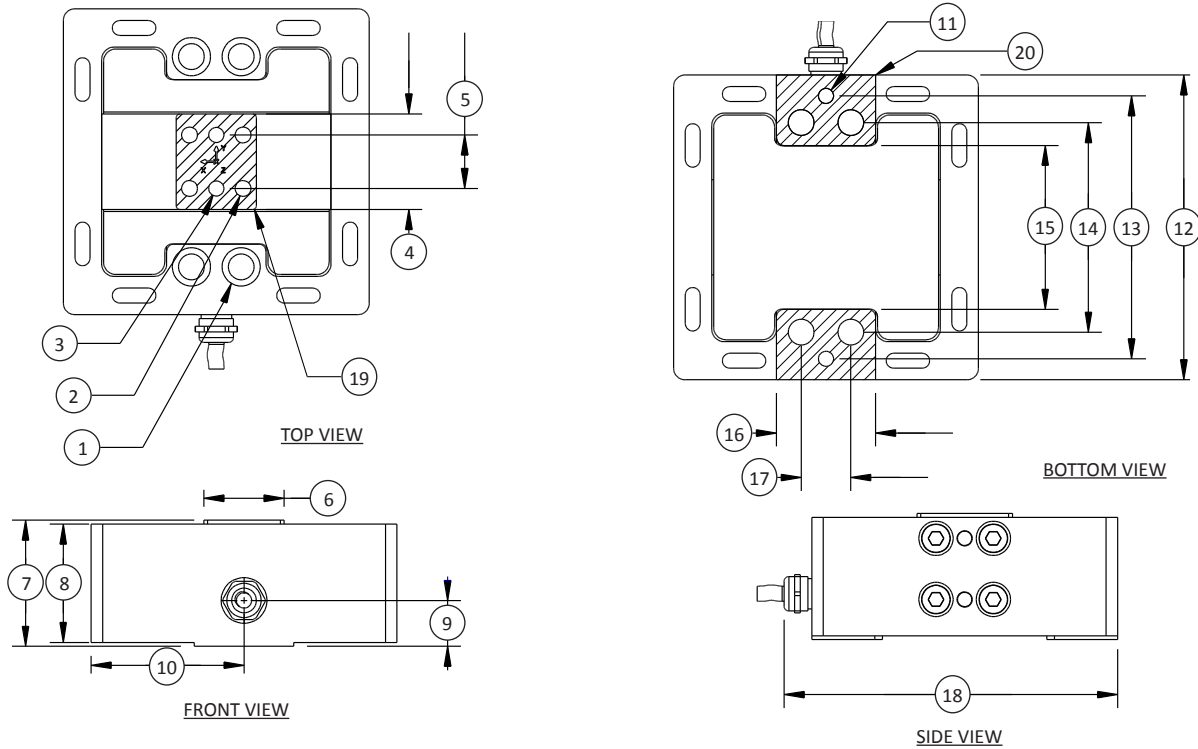

See Drawing	Metric	U.S.
	mm	in
(1)	4 x Ø14 THRU, □ Ø20 ∓ 13	4 x Ø0.6 THRU, □ Ø0.8 ∓ 0.5
(2)	4 x (M10x1.5) ∓ 15, ∨ 118°	4 x (M10x1.5) ∓ 0.6, ∨ 118°
(3)	2 x Ø8 H7 ∓ 15, ∨ 118°	2 x Ø(0.3156/0.3150) ∓ 0.6, ∨ 118°
(4)	50	2.0
(5)	28	1.1
(6)	42	1.7
(7)	66	2.6
(8)	62	2.4
(9)	24	0.9
(10)	80	3.1
(11)	2 x Ø8 H7 ∓ 5, ∨ 118°	2 x Ø(0.3156/0.3150) ∓ 0.2, ∨ 118°
(12)	160	6.3
(13)	138	5.4
(14)	110	4.3
(15)	86	3.4
(16)	52	2.0
(17)	26	1.0
(18)	174.5 (+1)	6.9 (+0.04)
(19)	Bolting Surface / Measuring Platform	
(20)	Bolting Surface	

U.S. dimensions and capacities are provided for conversion only. Standard product will be sold in kN and Metric dimensions. U.S. capacities available upon special request and at an additional cost.

## 3A300 SERIES 3-AXIS LOAD CELL (U.S. & METRIC)

### SPECIFICATIONS

### STANDARD CONFIGURATION

ACCURACY – (MAX ERROR*)				
Nonlinearity – %FS	±0.2			
Hysteresis – %FS	±0.1			
Creep, in 30 min – %	±0.5			
TEMPERATURE				
Effect on Zero – %RO / °C	±0.02			
Effect on Output – % / °C	±0.02			
Compensated Range	°C	-10 to +70		
	°F	+14 to +158		
Operating Range	°C	-10 to +85		
	°F	+14 to +185		
ELECTRICAL				
Rated Output (Nominal) – mV/V	±1			
Max. Excitation Voltage – V	10			
Zero balance – mV/V	0.1			
Input resistance, z axis – Ω	740 ±5			
Output resistance, z axis – Ω	700 ±5			
Input resistance, x/y axis – Ω	370 ±5			
Output resistance, x/y axis – Ω	350 ±5			
Insulation Resistance – Ω	> 5 × 10 <sup>9</sup>			
Electrical Connection – m	16-PIN Connector. Includes 5 mating cable with 37-PIN connector			
MECHANICAL				
Rated Capacity (FS)	N	50K	100K	200K
	lbf	11.2K	22.5K	45K
Material	Nickel plated steel			
Deflection – Fx, Fy	mm	±0.2		
	in	±0.008		
Deflection – Fz	mm	±0.4		
	in	±0.016		
Total Weight	kg	45		
	lbs	99.2		
Safe Overload – %RO	150			
Ultimate Overload – %RO	300			
Protection Level	IP54			
ECCENTRICITY AND MOMENT*				
Allowable moment	Nm	4K	8K	12K
	lbf-in	35.4K	70.8K	106K
Crosstalk: x:y / y:x – %	±1			
Crosstalk: z:x/y – %	±1			
Crosstalk: x/y:z – %	±2			
Eccentric Load Sensitivity – %FS @ 100mm	±1			



Model 3A300 (Shown)

\* Nominal

U.S. dimensions and capacities are provided for conversion only. Standard product will be sold in kN and Metric dimensions. U.S. capacities available upon special request and at an additional cost.



## 3A300 SERIES 3-AXIS LOAD CELL (U.S. & METRIC)

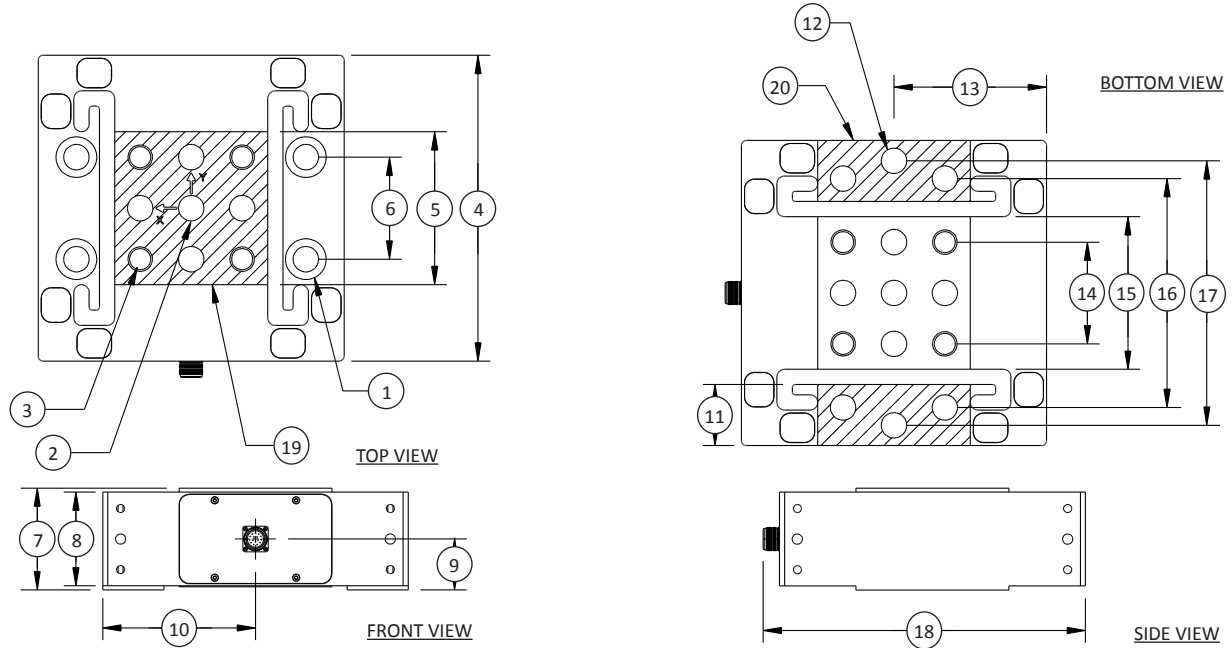

### DIMENSIONS

See Drawing	Metric	U.S.
	mm	in
(1)	4 x $\varnothing$ 25 THRU, $\sqcup$ $\varnothing$ 40 $\downarrow$ 30	4 x $\varnothing$ 1.0 THRU, $\sqcup$ $\varnothing$ 1.6 $\downarrow$ 1.2
(2)	5 x $\varnothing$ 25 H7 THRU	5 x $\varnothing$ (0.9851/0.9842) THRU
(3)	4 x (M24x3) THRU	
(4)	300	11.8
(5)	150	5.9
(6)	100	3.9
(7)	100	3.9
(8)	92	3.6
(9)	50	2.0
(10)	150	5.9
(11)	60	2.4
(12)	2 x $\varnothing$ 25 H7 $\downarrow$ 40	2 x $\varnothing$ (0.9851/0.9842) $\downarrow$ 1.6
(13)	150	5.9
(14)	100	3.9
(15)	150	5.9
(16)	225	8.9
(17)	260	10.2
(18)	316	12.4
(19)	Bolting Surface / Measuring Platform	
(20)	Bolting Surface	

Datasheet 3A v2.4 03-11-2019

U.S. dimensions and capacities are provided for conversion only. Standard product will be sold in kN and Metric dimensions. U.S. capacities available upon special request and at an additional cost.

## 3A400 SERIES 3-AXIS LOAD CELL (U.S. & METRIC)

### SPECIFICATIONS

### STANDARD CONFIGURATION

ACCURACY – (MAX ERROR*)		
Nonlinearity – %FS		±0.2
Hysteresis – %FS		±0.1
Creep, in 30 min – %		±0.05
TEMPERATURE		
Effect on Zero – %RO / °C		±0.02
Effect on Output – % / °C		±0.02
Compensated Range	°C	-10 to +70
	°F	+14 to +158
Operating Range	°C	-10 to +85
	°F	+14 to +185
ELECTRICAL		
Rated Output (Nominal) – mV/V		±1
Max. Excitation Voltage – V		10
Zero balance – mV/V		0.1
Output resistance, z axis – Ω		340 ±5
Input resistance, x/y axis – Ω		370 ±5
Insulation Resistance – Ω		> 5 × 10 <sup>9</sup>
Electrical Connection – m		16-PIN Connector. Includes 5 mating cable with 37-PIN connector
MECHANICAL		
Rated Capacity (FS)	N	500K
	lbf	112K
Material		Nickel plated steel
Deflection – Fx, Fy	mm	0.3
	in	0.01
Deflection – Fz	mm	0.6
	in	0.02
Total Weight	kg	120
	lbs	4.7
Safe Overload – %RO		150
Ultimate Overload – %RO		300
Protection Level		IP54
ECCENTRICITY AND MOMENT*		
Allowable moment	Nm	15K
	lbf-in	133K
Crosstalk: x:y / y:x – %		±1
Crosstalk: z:x/y – %		±1
Crosstalk: x/y:z – %		±1
Eccentric Load Sensitivity – %FS @ 100mm		±1



**Model 3A400 (Shown)**

\* Nominal

U.S. dimensions and capacities are provided for conversion only. Standard product will be sold in kN and Metric dimensions. U.S. capacities available upon special request and at an additional cost.

## 3A400 SERIES 3-AXIS LOAD CELL (U.S. & METRIC)

### DIMENSIONS

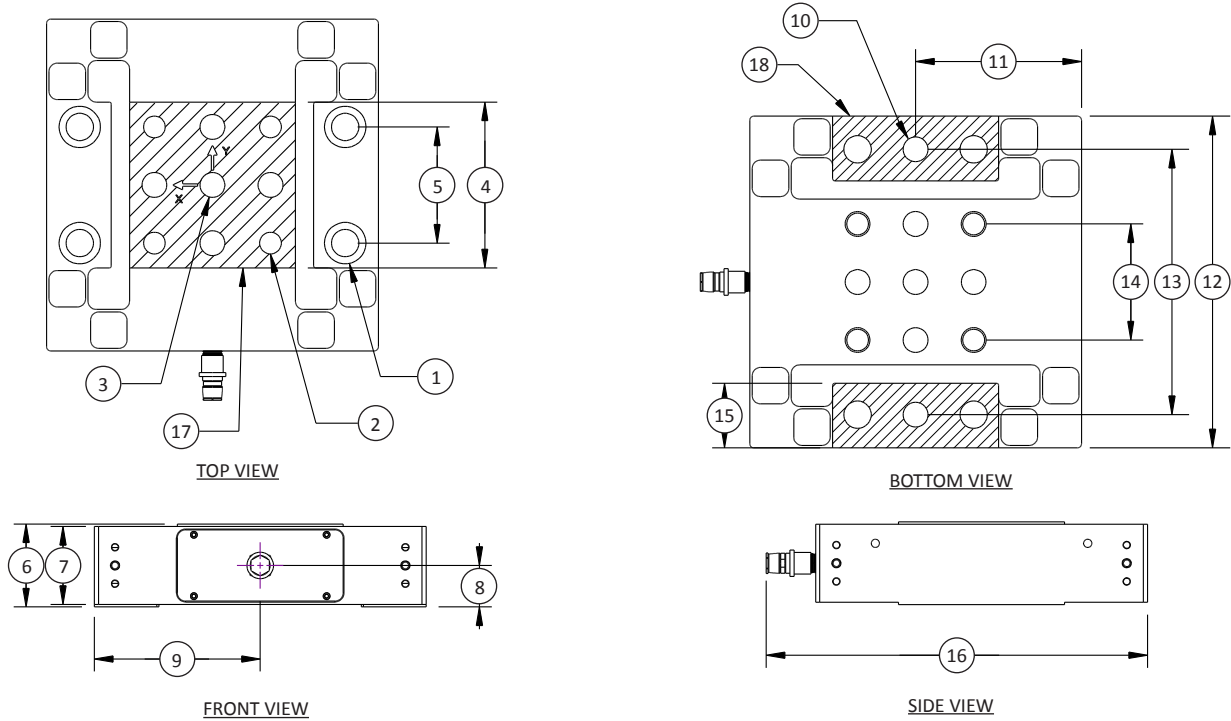

See Drawing	Metric	U.S.
	mm	in
(1)	4 x $\varnothing$ 33 THRU, $\sqcup$ $\varnothing$ 50 $\downarrow$ 36	4 x $\varnothing$ 1.3 THRU, $\sqcup$ $\varnothing$ 2.0 $\downarrow$ 1.4
(2)	4 x (M30x3.5) THRU	4 x (M30x3.5) THRU
(3)	5 x $\varnothing$ 30 E7 THRU	5 x $\varnothing$ (1.1835/1.1827) THRU
(4)	200	7.9
(5)	140	5.5
(6)	100	3.9
(7)	94	3.7
(8)	50	2.0
(9)	200	7.9
(10)	2 x $\varnothing$ 30 E7 $\downarrow$ 40	2 x $\varnothing$ (1.1835/1.1827) $\downarrow$ 1.6
(11)	200	7.9
(12)	400	15.7
(13)	320	12.6
(14)	140	5.5
(15)	78	3.1
(16)	460 (+5)	18.1 (+0.2)
(17)	Bolting Surface / Measuring Platform	
(18)	Bolting Surface	

Datasheet 3A v2.4 03-11-2019

U.S. dimensions and capacities are provided for conversion only. Standard product will be sold in kN and Metric dimensions. U.S. capacities available upon special request and at an additional cost.